

Outdoor-use Universal Wall Mount Bracket

Unit: [Inch]
mm

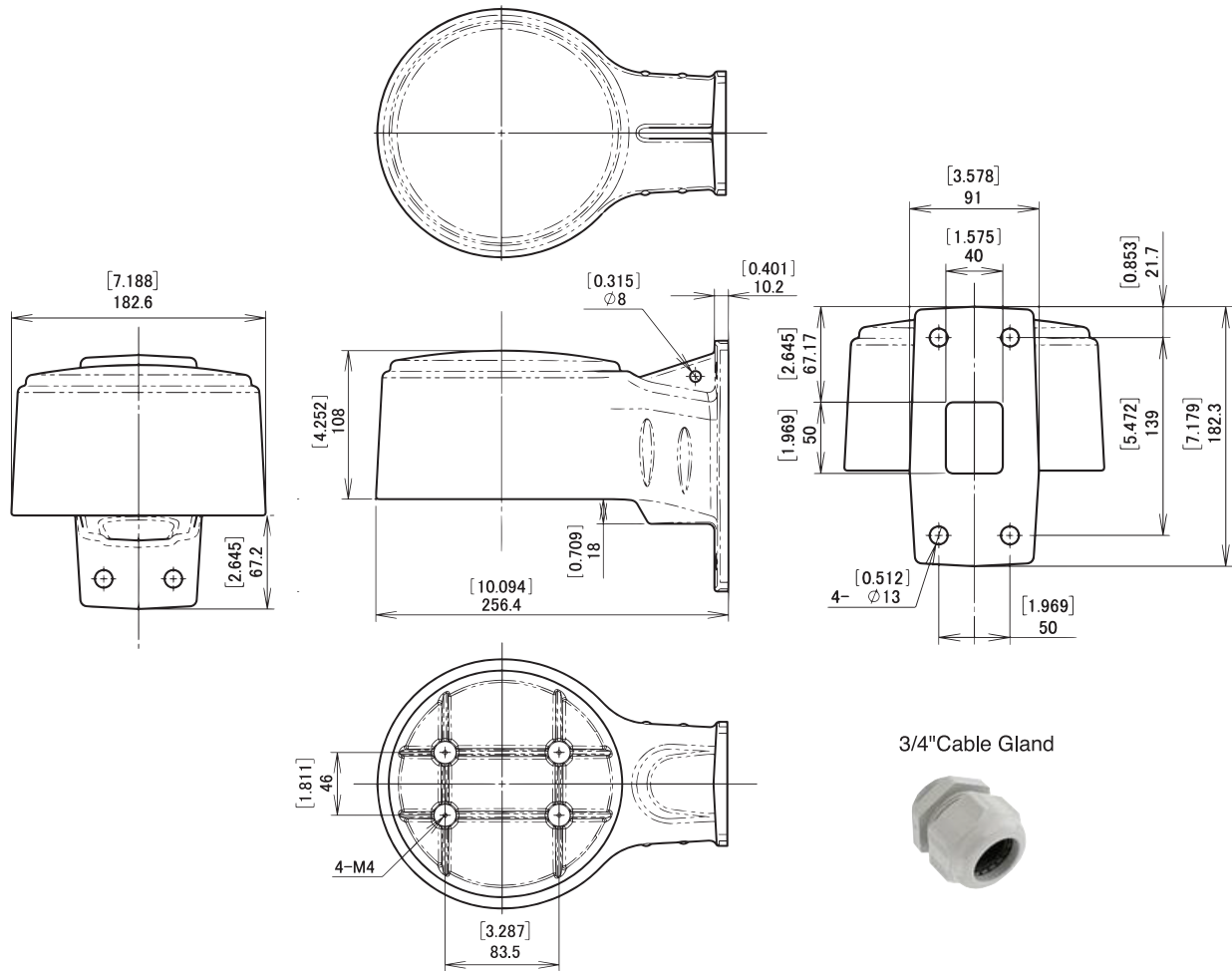

For IP66 Vandal Resistant Dome Camera(Max.Acceptable Dia of Camera $\varnothing 160$ mm)

【Outdoor-use Universal Wall Mount Bracket】

A-SWD5ZWB2



"Optional" Two-Coat system for Metal Parts(Bracket) for corrosion protection
Nothing = Standard One Coat by UV resistant polyester powder coat
-TC = "Optional" Two-Coat

Specification	
Camera Compatibility	IP66, Max. Dia $\varnothing 160$ mm(6.299")
Material	Aluminum
Paint	Offwhite(RAL9002) Powder Coat Finish
Weight	Approx. 1.5kg(3.31 lbs)
Accessories	3/4"NPT Cable Gland x 1 Screws
Camera Mount Pattern	To be arranged before shipment.
Optional Items	Safety Wire A-SW1000L Pole Mount Adapter A-BK3, A-BK4 Corner Mount A-CM3
Standard	RoHS

*Note: Specifications are subject to change without prior notice.